



DBG

TEMPERATURE & PRESSURE CONTROLS

- Vibration Proof to 15G.
- With or Without Setting Scales.
- Available with 2 Switches for Alarm and Shutdown.
- IP55 Rating.
- Three Basic Switch Configurations:
 - Pressure Safety Only,
 - Pressure & Temperature Safety,
 - Temperature Safety Only.

Application.

The DBG range comprises robustly constructed and reliable controls designed specifically for the protection and safety of a wide range of high value mobile or stationary plant for land-based or marine applications, including use on Engines, Pumps, Compressors, Generators and Gear Boxes.

Physical Description.

It is a versatile instrument which can incorporate a thermal & pressure switch in a single unit to provide dual protection against temperature and pressure hazards. Alternatively pressure only or temperature only versions are available, with or without alarm. Temperature sensing is via a rigid stem and mount directly onto the engine. All models include a functionally styled die-cast aluminum case with Polycarbonate covers.

Operation.

The thermostat system comprises a bellow integral with a rigid extension tube and sensing phial for direct mounting. To achieve correct thermal



Model shown DBG/AM

operation and rapid response, the stem must be immersed to its maximum depth. In the low pressure system compactness and stability are gained with the use of a diaphragm; the high pressure models have 'Bellofram' diaphragm giving long life at higher pressures.

Installation Considerations.

The DBG can be mounted in any attitude without affecting the operating characteristics. For applications with severe vibration problems, all models are designed to withstand acceleration up to 15g. Full details of the vibration characteristics within which the DBG will operate are shown in the table on page 5.





DBG MODELS

Pressure Safety Only

Non Standard DBG Variants

Single Switch with Setting Scale

Model	Range Bar	Mid Range Differential Bar Nominal	Max Pressure Bar	Pressure Connection
TB1	0.2 – 3.5	0.5	25	¼ " BSPF
TB2	2 – 12	1.2	35	
TB3	10 – 32	3.2	50	
TB4	30 – 52	5.5	80	
TB5	2 – 18	2.0	35	
IVSV001	2 - 12	1.2	35	

IVS 001 has a 2 pole male adapter.

Single Switch – Non Scale

Model	Range Bar	Mid Range Differential Bar Nominal	Max Pressure Bar	Pressure Connection
EJI	0.2 – 3.5	0.5	25	¼ " BSPF
EHI	0.2 – 3.5	0.5	25	¼ " BSPF
EJIA	0.2 – 3.5	0.5	25	¼ " BSPF Rt. Ang.

2 Switches (Alarm & Shutdown) – Non Scale

Model	Range Bar	Mid Range Differential Bar Nominal	Max Pressure Bar	Pressure Connection
DG1/1	0.2 – 3.5	0.5	25	¼ " BSPF
DG1/2	2 – 12	1.2	25	
DG1/1A	0.2 – 3.5	0.5	25	¼ " BSPF RtAng.

Internal nominally 0.3 bar.

Accessory Chart DBG Pressure

	Mounting Brackets		Conduit Adapters				Others	
	With 4 Terminal receptacles and boots	With 4 Terminal receptacles and boots	DBG PA 351 PG 13.5	DBG PA 380 M20 X 1.5	DBG PA 383 PG 11	DBG PA 567 M20 X 1.5 FOR SIDE BRACKET	DBG PA 739 CONDUIT PAD AND GASKET	DBG PA 817 ADJUSTING PINS
DBG/DG		•	•	•	•	•	•	•
DBG/EH	•		•	•	•	•	•	•
DBG/EJ		•	•	•	•	•	•	•
DBG/EJIA			•	•	•	•	•	•
DBG/IVS		•	•	•	•	•	•	
DBG/TB		•	•	•	•	•	•	

□ Optional Extra • Supplied with DBG





ARS ANGLIAN DIESELS

Temperature & Pressure Safety

2 Switches – Stem – Non Scale.

Model	Range °C	Diff °C nominal	Max Temp °C	Stem L x φ	Range bar	Max diff bar	Max press bar	Pressure connection
AM1/1	43 – 99	4	125	62mm x 12.7mm	0.2 to 3.5	0.4	25	¼" BSPF
AM2/1	90 – 132	4	155					
AM3/1	124 – 160	7	185					
AM4/1	149 – 177	7	200					
AM5/1	15 – 60	4	105					
AM1/2	43 – 99	4	125	62mm x 12.7mm	2 to 12	1.2	25	¼" BSPF
AM2/2	90 – 132	4	155					
AM3/2	124 – 160	7	185					
AM4/2	149 – 177	7	200					
AM5/2	15 – 60	4	105					

	Phial Glands				Phial Pockets			Mounting Brackets	Conduit Adapters				Others	
	DBG PA 246 3/8" BSP Brass for 9.5mm dia. phials	DBG PA 247 1/2" BSP Brass for 9.5mm dia. phials	DBG PA 518 1/2" BSP S/S long for 12.7mm dia. Phials	DBG PA 8216 1/2" BSP S/S short for 12.7mm dia. phials	DBG PA 248 1/2" BSP Brass for 9.5mm dia. phials	DBG PA 559 1/2" BSP S/S 62mm Stem models only	DBG PA 696 1/2" NPT for 9.5mm dia phials	DBG 252 bracket only	DBG PA 351 PG 13.5	DBG PA 380 M20 X 1.5	DBG PA 383 PG 11	DBG PA 567 M20 X 1.5 FOR SIDE BRACKET	DBG PA739 CONDUIT PAD AND GASKET	DBG PA817 ADJUSTING PINS
AM			•	•		•			•	•	•	•	•	•
FPA	•	•			•		•	•	•	•	•	•	•	•
FPB									•			•	•	•

• Optional Extra • Supplied with DBG





ARS ANGLIAN DIESELS

Temperature Safety Only

Single switch – Stem – with Setting Scale.

Model	Range °C	Diff °C nominal	Max Temperature °C	Stem L x φ	Max external bulb pressure
SB1	40 – 110	6	127	62mm x 12.7mm	14 bar
SB2	90 – 150	6	170		
SB3	120 – 200	6	231		
SB4	150 – 240	6	262		
SB5	15 - 60	4	105		

Also available are SC models with the above characteristics but with a longer stem (107mm maximum).

2 Switches (Alarm & Shutdown) – Stem – Non Scale.

Model	Range °C	Diff °C nominal	Max Temperature °C	Stem L x φ	Max external bulb pressure
BM1	43 – 99	4	125	62mm x 12.7mm	14 bar
BM2	90 – 132	4	155		
BM3	124 – 160	7	185		
BM4	149 - 177	7	200		

Interval nominally 5°C

Accessory Chart DBG Temperature

	Phial Glands				Phial Pockets			Mounting Brackets		Conduit Adaptors			Others		
	DBG PA 246 3/8" BSP Brass for 9.5mm dia. phials	DBG PA 247 1/2" BSP Brass for 9.5mm dia. phials	DBG PA 518 1/2" BSP S/S long for 12.7mm dia. phials	DBG PA 8216 1/2" BSP S/S short for 12.7mm dia. phials	DBG PA 248 1/2" BSP Brass for 9.5mm dia. phials	DBG PA 559 1/2" BSPS/S 62mm Stem models only	DBG PA 696 1/2" NPT for 9.5mm dia phials	DBG 252 bracket only	DBG PA 672 4 terminal receptacles & boots	DBG PA 351 PG 13.5	DBG PA 380 M20 X 1.5	DBG PA 383 PG 11	DBG PA 567 M20 X 1.5 FOR SIDE BRACKET	DBG PA739 CONDUIT PAD AND GASKET	DBG PA817 ADJUSTING PINS
BM			•	•		•				•	•	•	•	•	•
SB			•	•		•				•	•	•	•	•	

• Optional Extra • Supplied with DBG





Technical Details

Switch Ratings (Single pole double throw changeover).

Volts	DC Amps		AC Amps	
	Res	Ind	Volts	Res
12	15	15	12	15
24	10	10	24	10
125	0.5	0.05	125	0.5
250	0.25	0.03	250	0.25

Approximate Weights

Model	kg.
AM	0.67
BM	0.61
DG	0.51
EJ.EH	0.50
IVS	0.58
SB	0.61
TB	0.52

Connections 4.8mm x 0.5mm quick connect terminals

Functions	DBG Models	Terminals					
		1	2	3	4	5	6
Temp	FDA SB	C	MOR	BOR	—	—	—
	GM/DBG BM	C	Alarm BOR	MOR	C	Shutdown BOR	MOR
Pressure	EH, TB, EJ, IVS	C	BOF	MOF	—	—	—
	DG	C	Shutdown BOF	MOF	C	Alarm BOF	MOF
Temp & Pressure	FPB AM	C	Pressure BOF	MOF	C	Temperature BOR	MOR

C = Common

BOF = Break on Fall

MOF = Make on Fall

Vibration Characteristics (All Models)

Amplitude – 4mm peak. Frequency Range 5 to 50Hz.

Acceleration – 15g. Frequency Range 30 to 250Hz.

The above characteristics apply only to within 0.2 bar (pressure) or 2°C (temperature) to the point at which the model is set.

Ordering Information

Model reference Set Point (°C and/or bar) Conduit connection Accessories

DBG/ ●● / ●●● / ●● / ●●





ARS ANGLIAN DIESELS

Outline Details

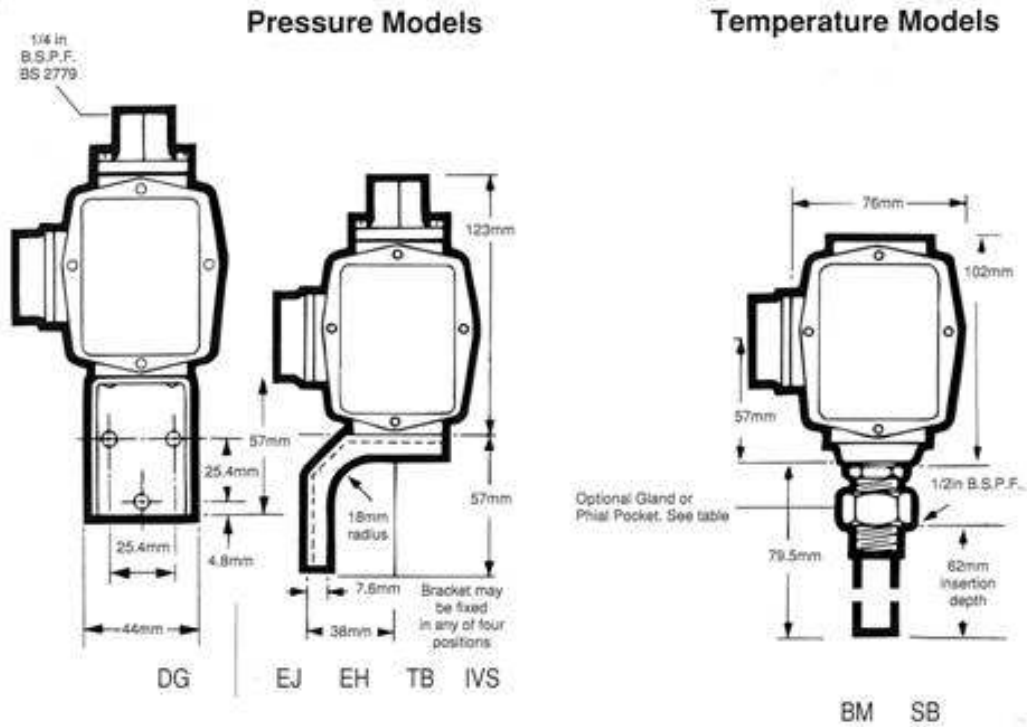

Temperature and Pressure Models

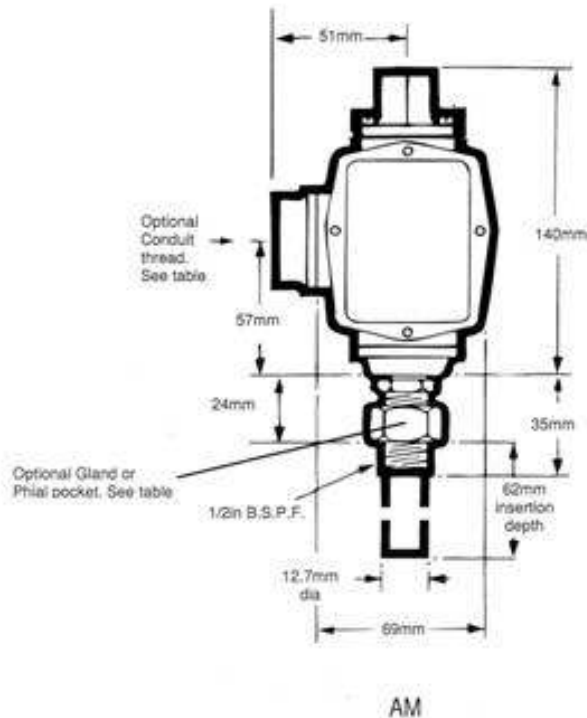

ARS Anglian Diesels Limited
Unit 51 Monckton Road Industrial Estate
Denby Dale Road
Wakefield
West Yorkshire
WF2 7AL

Tel: 01924 332492
Fax: 01924 332493

enquiries@arsangliandiesels.co.uk
<http://www.arsangliandiesels.co.uk>

